

MANISCOPIC

MRT 2150 *M Series*



- Lift height : 20.60 m
- Max. reach : 18.10 m
- Engine : 132 HP - 97 kw
- 4 wheel drive - 4 wheel steer
- Hydrostatic transmission
- Levelling system

 **MANITOU**

ROTATION ON STABILISERS FULLY EXTENDED WITH FORKS

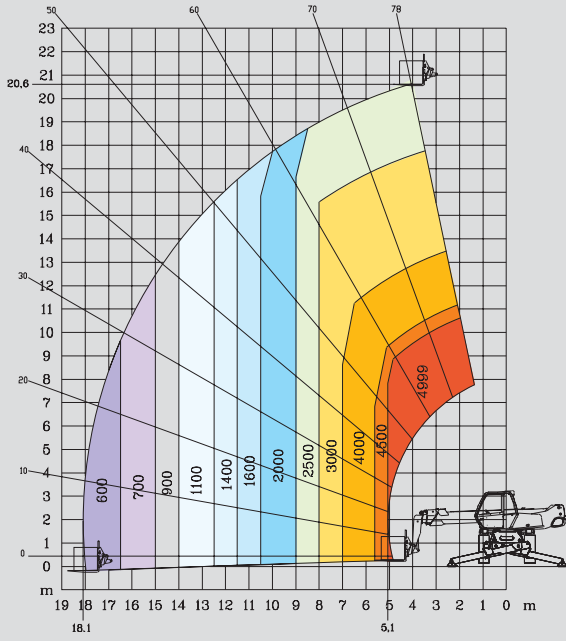

FRONTAL POSITION ON WHEELS WITH FORKS

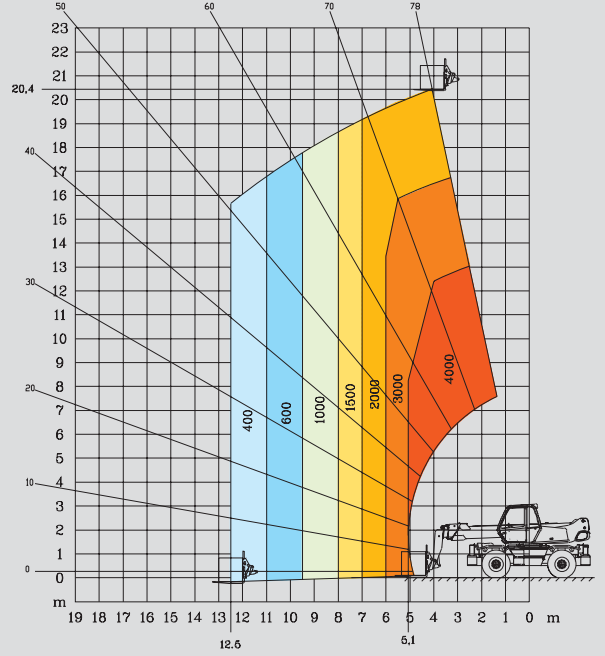

ROTATION ON STABILISERS NOT FULLY EXTENDED WITH FORKS

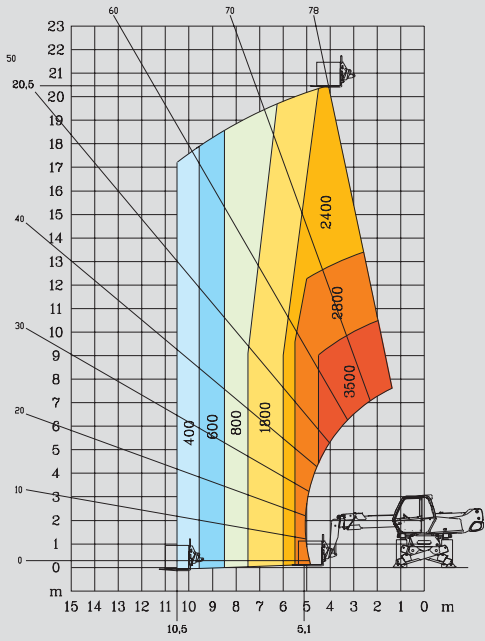

ROTATION ON STABILISERS FULLY EXTENDED WITH 5T WINCH

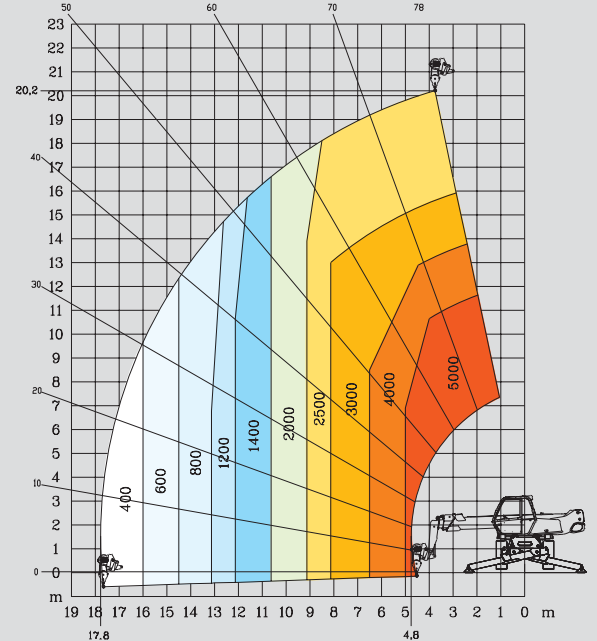

ROTATION ON STABILISERS FULLY EXTENDED WITH JIB P 600

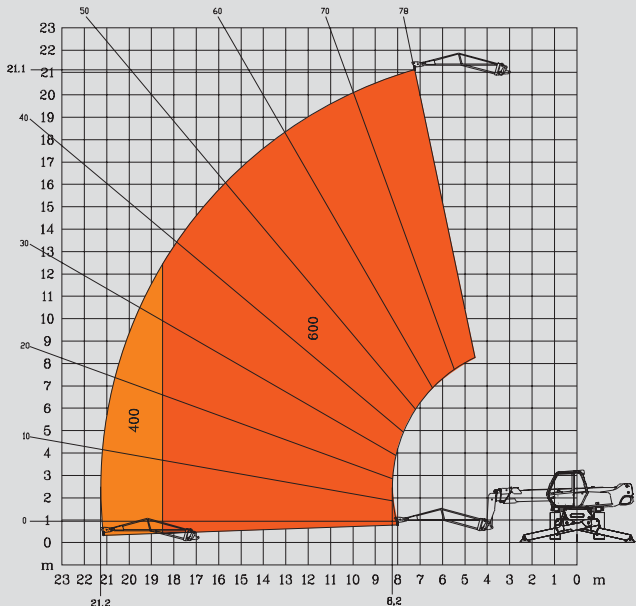

ROTATION ON STABILISERS FULLY EXTENDED WITH JIB P 1500

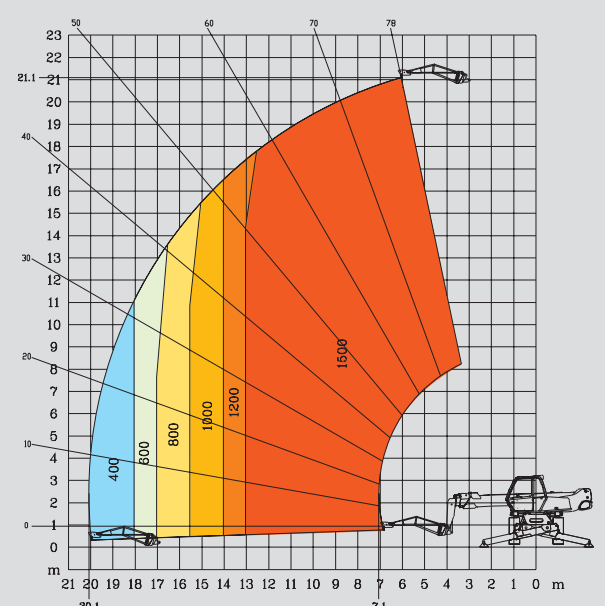

ROTATION ON STABILISERS FULLY EXTENDED WITH EXTENSIBLE PLATFORM 2,25/4 m

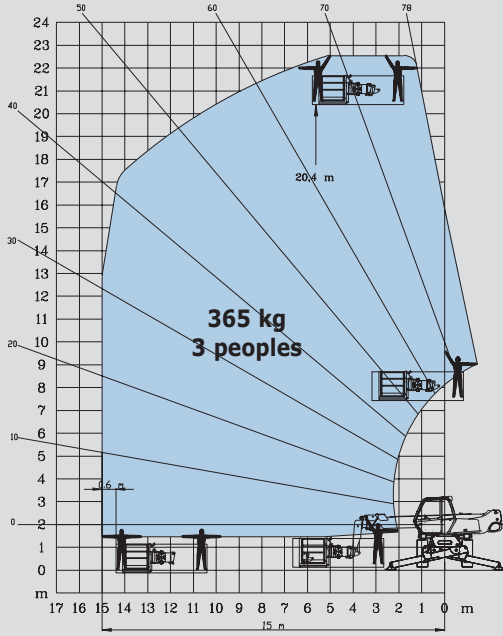

ROTATION ON STABILISERS FULLY EXTENDED WITH 1000 KG PLATFORM 2,25/4 m

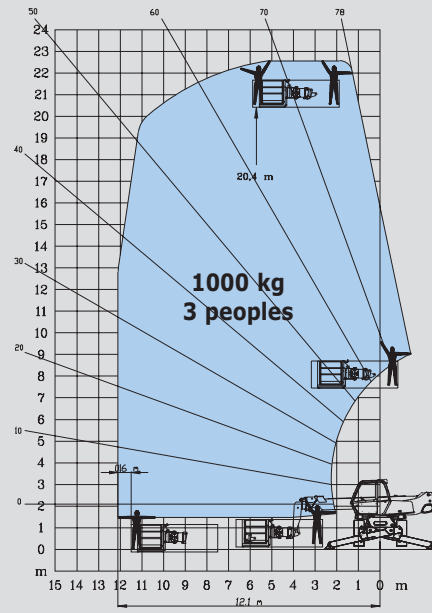

ROTATION ON STABILISERS FULLY EXTENDED WITH 3 D SYSTEM IN POSITIVE POSITION

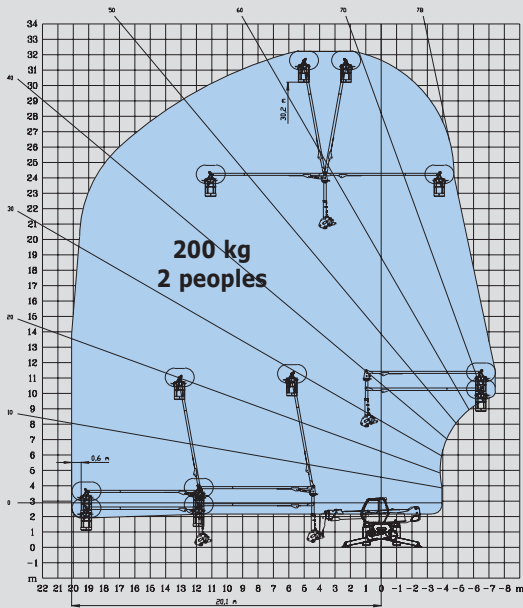

ROTATION ON STABILISERS FULLY EXTENDED WITH 3 D SYSTEM IN NEGATIVE POSITION

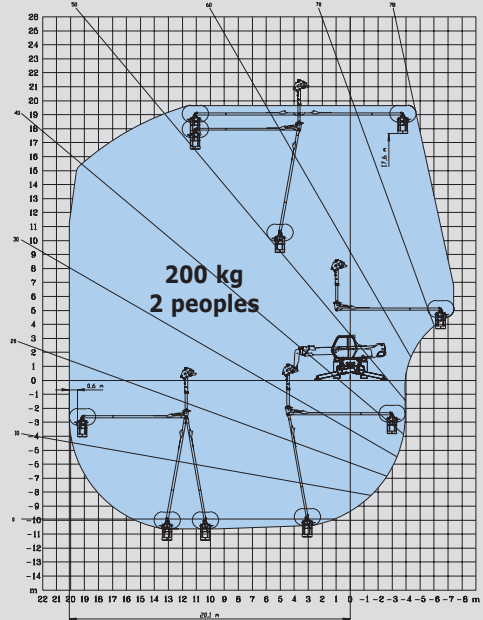







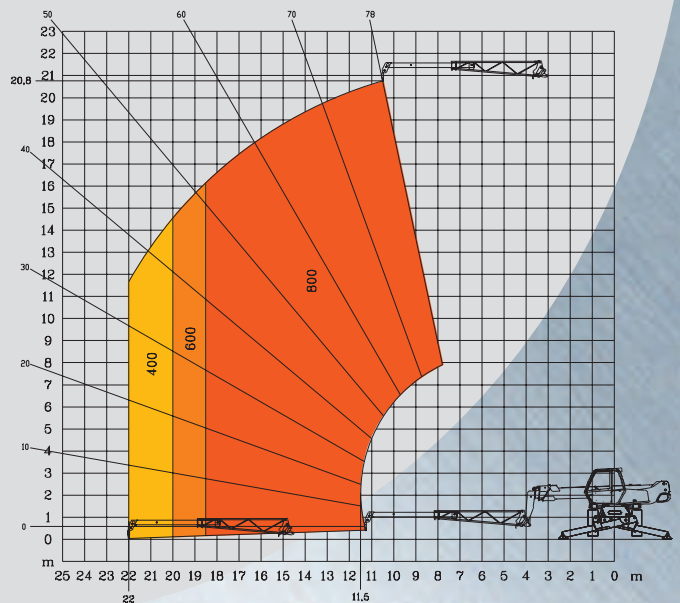







ROTATION ON STABILISERS FULLY EXTENDED WITH AERIAL JIB PLATFORM



ROTATION ON STABILISERS FULLY EXTENDED WITH CRANE JIB



MRT 2150 *M Series*

-  **Lift capacity** (on stabilisers)4999 kg
at 500 mm from forks heels
-  **Lift height** :20.60 m
-  **Tyres**
18 - 22,5
-  **Forks** (mm)
Length.....1200
Width x thickness.....150 X 50
-  **Multidisc brakes** : hydraulically assisted on both axles
Negative parking brake
-  **Engine PERKINS**
Type1104C - 44 TA
Capacity.....4 cyl. 4400 cm³
Power (ISO/TR 14396).....132 HP/97 kw
500 Nm at 1400 rpm
Water cooling
Direct injection
-  **Transmission**hydrostatic
With automatic power regulation (hydraulic variable
displacement pump and motor)
Reversing shiftelectromagnetic
2 speed forward and reverse
Travel speed.....25 km/h
-  **Rear axle**
Frame levelling on front axle +/- 8° (15%)
Automatic rear axle locking system
over 15° rotation
-  **4 stabilizers**
simultaneous or individually controlled
-  **Total and continuous rotation**
Turret mounted on a double slew ring
Hydraulic and electric rotation
-  **Hydraulics**
3 pumps gear type270 bars/160 l/mn
-  **Control** : 2 electro proportional control joysticks for all
hydraulic movements
-  **Capacities**
Cooling system.....15 l.
Engine oil.....11.5 l.
Hydraulic oil200 l.
Fuel tank230 l.
-  **Weight unladen** (with forks)16095 kg
Overall width.....2.43 m
Overall height3.02 m
Overall length6.78 m
Ground clearance0.37 m
Drawbar pull10800 daN
-  **Standard load moment indicator**
(mobile crane standards)

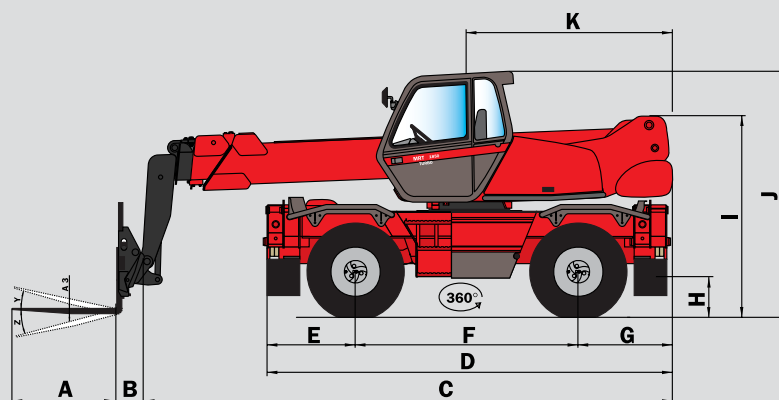

A	1200
A1	150
A2	1030
A3	60
B	290
C	6490
D	5050
E	1155
F	2750
G	1155
H	370
I	2420
J	3025
K	2485
L	1930
M	2425
N	4700
O	5100
P	200
Q	4500
R	3800
S	4550
V	950
Y	12°
Z	105°

mm

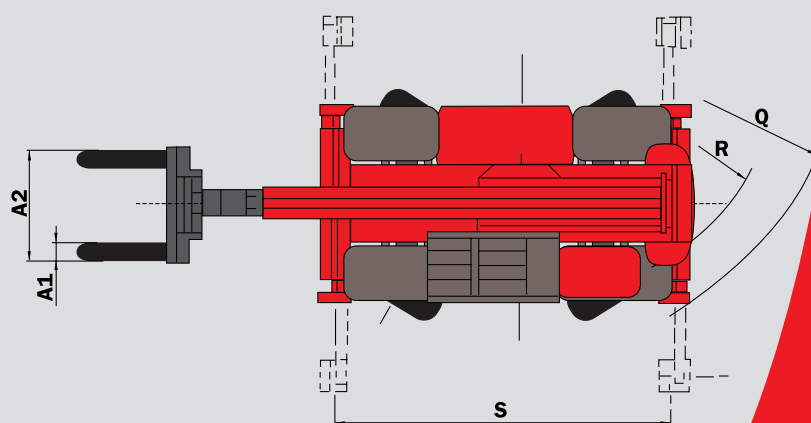
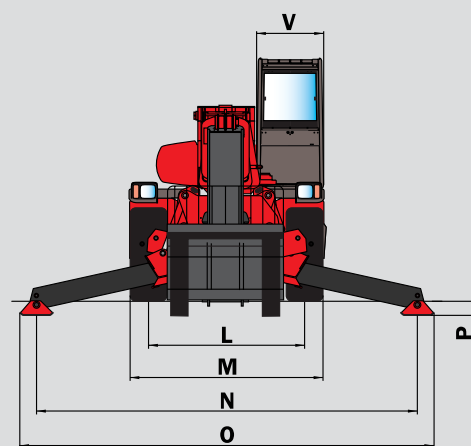

This publication in no way constitutes an offer and the company reserves the right to alter specification without prior notice.
The MANITOU models presented in this brochure can be supplied complete with optional equipment attachments.



MANITOU BF SA

B.P. 249 - 44158 Ancenis Cedex - France
Tél. : 33 2 40 09 10 11 / Export Department Fax : 33 2 40 09 10 97
www.manitou.com

700039EN

